

PARAMETRIZATION OF EFFECT OF METRO WAGON BASIC STRUCTURE DOOR FORCE MODEL

Miroslav Blatnický, Jan Dizo

University of Zilina, Slovakia

miroslav.blatnický@fstroj.uniza.sk, jan.dizo@fstroj.uniza.sk

Abstract. We live in the age, when the speed and quality are in the front partitions of transport. Time between a presentation of a concept and production of a prototype is still shorter. There is mainly the field of automatization of systems. Purely mechanic systems are used in many branches less and less. This is also the case with the issue of a metro door presented by the authors. Manual opening of a door is not currently used. This manner of door opening has been replaced by pneumatic and electric systems. In the process of door design for the solved metro wagon, a pre-sliding type of a door was designed. In case of a metro vehicle, where opening and closing of the door is relatively often, the door and door mechanisms are significantly loaded. By this reason, extraordinary reliability requirements of their functionality have to be taken into account. These forces represent the effect of the door system on a wagon basic structure. Because this problem is quite large, the authors do not present all details related with the design of the door system, however, in this article, they focus mainly on parametrization of a model, which will serve for calculation of loading forces, methodology of creation of equations for calculation of the loads due to the pressure differences, as well as normative requirements in terms of other loads. In order to speed up the process of further proposals, the authors present the methodology of the process of parametrization for determination of force effects in the important structural unit.

Keywords: wagon basic structure, door system, parametrization, calculation model, force effects.

Introduction

One of possibilities, how to solve a problem of transportation lot of people in many cities, is to use metro. It allows to transport large numbers of people in more efficient way than road transport, it does not cause traffic jams, risk of potential accidents is lower, and operation of metro is more environmentally friendly [1; 2]. Metro, which is also called as an underground railway, is a transport system, which includes many elements of the needed infrastructure [2-4]. A carriage, or a wagon, is the very important element of the metro infrastructure. Metro wagons usually form a train unit. Metro wagons are operated in combined operational conditions [5; 6], which include running underground in tunnels, overground, where wagons are exposed to various and often to extreme weather conditions etc. [7], as well as in various track geometries [8-11]. Based on these facts, the design of a metro wagon has to meet quite strict requirements. On the one hand, they relate with an integration of the structure and thus with safety [12-15], and on the other hand, wagons have to offer sufficient space and comfort for passengers [16-19]. A presented topic relates with a design of a door system, which is intended to be used on metro wagons of a commercial operator [20]. There are more technical solutions of opening of a metro door. Considering given requirements, the designed pre-sliding door works based on a combination of two movements. It includes a retractable movement, which pushes out the door from the wagon body wall to a certain position. Then, the sliding movement along the wagon body wall is performed. The retractable movement is most often in the range of 58 to 65 mm. The effort is to reach as small value as possible. It allows to occupy a smaller space [21]. The advantage of this door is the fact that in the closed position it is in the body sidewall plane. Thus, such a solution is suitable for mechanical washing, it is more esthetical and it seals better. The disadvantage is a guidance or a driving system, which is usually more complicated in comparison with other technical solutions of metro doors. The design of the door was preceded by an extensive study of standards and requirements, which had to be observed. The results of these analyses are published in [22; 23]. Besides of these presented results, the authors have also taken into account the requirements of fire protection. Fire protection must be defined in the technical specifications for the door, as well as for the door equipment. They ensure the total requirements for a protection of a whole vehicle against fire. The standard EN 45545-2 [24; 25] must be fulfilled necessarily. Further, the technical specification has to include requirements of noise insulation, which will meet all criteria for the whole vehicle [26]. Experiments of noise measurements will be performed in compliance with the EN ISO 10140-2 [27; 28]. The thermal insulation is designed based on the ISO 12567-1 standard [29]. Finally, all electric and electronic devices must meet the requirements in EN 50155 and EN 50121-3-2 standards [30; 31] and the used software must correspond

to so-called SSIL - Software Safety Integrity Level [22]. All safety requirements are proven by the following factors:

- the door must be opened by the speed lower than $3.0 \text{ km}\cdot\text{h}^{-1}$;
- failure of the emergency opening system of two opposite doors;
- opening of two doors non-adjacent to a platform, on the opposite side to a platform or without a platform;
- a signal “Open/Closed”, however, the doors are still open;
- a testing object is not detected in case of getting stuck in the door system;
- closed stairs improperly detected as open, which allows to open the door and thus also to fall a passenger on a railway track [22].

Moreover, an electrical equipment must be designed in such a manner that it will avoid a direct as well as indirect contact with alive electrical elements in compliance with the EN 50153 standard [32]. The door must restrict to penetrate water into a closed wagon. There is specified a level of airtightness for a whole wagon and in compliance with standardized values [33], the corresponding maximal limited escape area for pressure levels is determined [34]. The authors' designed technical solution of the door allows to control it by crews of a vehicle or by an automatic opening system. A mechanical locking system ensures that the doors are locked and held in the locking position, while released by an opening signal [23; 35]. In case of a manual control, the locking device must be handable by a hand by a maximal force of 20 N. A door, which is out of order, must be lockable from inside and/or outside of a wagon. This device for the locking of a door, which are out of order, has to be designed to be controlled manually only by an authorized operator. A technical design must also ensure that a device is not activated in a case of sudden acceleration or deceleration [36]. The admissible height from inside has not to be lower than $l_1 = 400 \text{ mm}$ over a plane of an opposite floor and outside has not to be more than $l_2 = 1700 \text{ mm}$ over a rail top [34].

Materials and methods

Geometry, attachment and considered loads of doors are presented in [22; 23]. The first step of the design of a parametric model of the door is introduced in [23]. By means of the designed model, it will be possible to calculate external forces and reactions, which represent acting the door system on a basic wagon structure. As the described problem is quite large, it is not possible to introduce and describe the entire methodology for calculation in details, where the procedure of setting up of three loading forces (inertia effects) in all three directions are determined [22; 23].

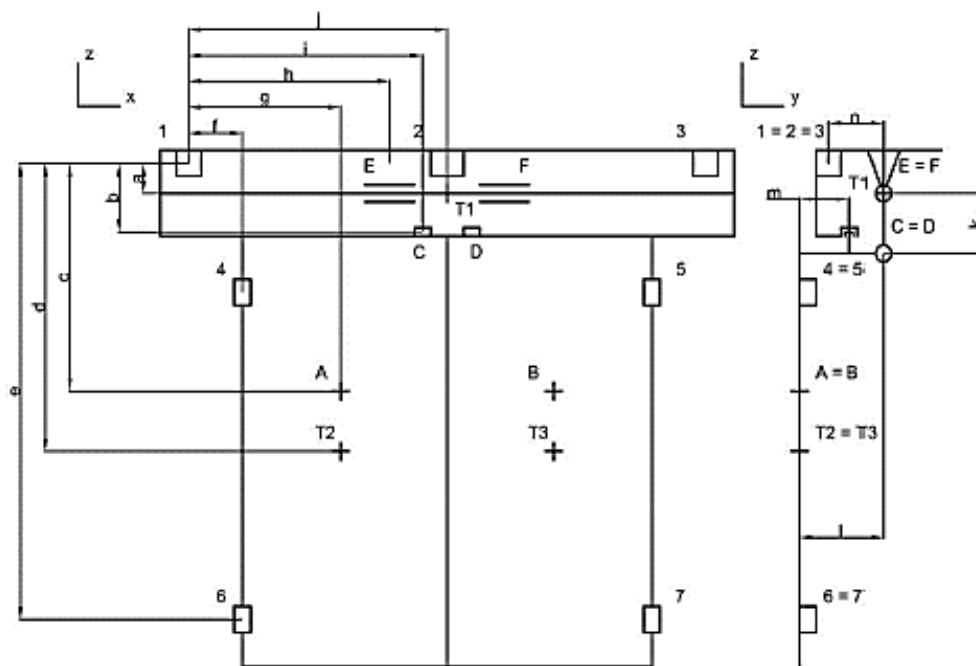

Fig. 1. Model of the designed door with indicated dimensions

Table 1

Values of dimensions depicted in Fig. 1

Dimension	Value, m	Dimension	Value, m
a	0.0250	h	0.7435
b	0.0980	i	0.8226
c	0.8610	j	0.8780
d	1.1270	k	0.1205
e	2.0710	l	0.1730
f	0.1470	m	0.1170
g	0.4875	n	0.0600

Individual dimensions of the door system are defined and obtained by means of the model created in Catia software. Here, the authors introduce a methodology of creation of equations for load of the door. Forces are generated due to difference of pressures outside and inside of a wagon, normative forces generated by passengers and by effects of the door gaskets. The first considered for is the force of the difference of pressures outside and inside of a wagon, denoted F_{TL} . This force arises due to the normative considered difference pressures [36] and its value is $p = \pm 1\ 900$ Pa. The force is reduced to the centres of gravity of individual parts of the door (wings) denoted T_2 a T_3 (Fig. 1). Dimensions of the metro door are listed in Table 1.

Using the symmetry, we can take into account just a half of the model (both wings are the same). Reactions generated in locations of the door's attachment come from the design itself [6]. A scheme, which is shown in Fig. 1, we need to depict in a side view (Fig. 2). In this figure, the considered force due to the difference of pressures is implemented. Due to a symmetry, we can consider, that forces are in the following relation $F_{y1} = F_{y3}$, as well as $F_{y6} = F_{y7}$. It means, they are the same on both sides of the door system (Fig. 1, Fig. 2). The force value F_{TL} is quantified of 3.082 N. The input values of the geometry and the loads are given in [23].

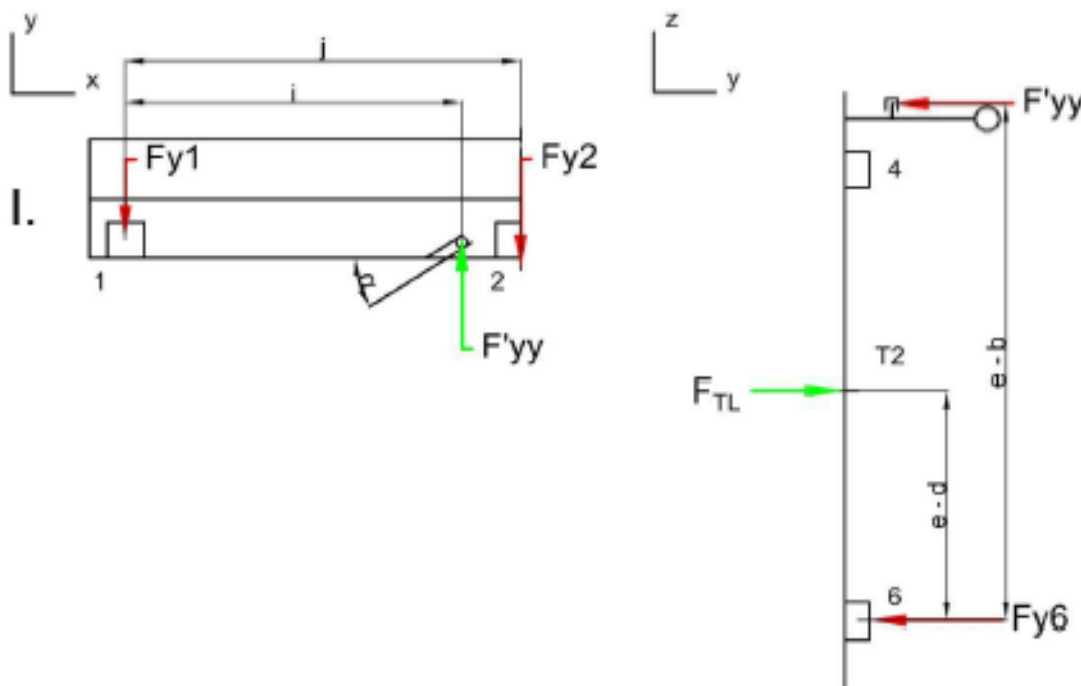

Fig. 2. Application of the law of action and reaction of forces on a door wing due to the force F_{TL}

The equations of equilibrium of air pressure are given by the following formulations (1-4), where variables are depicted in Fig. 2:

$$\sum_i F_{iy} = 0 \Rightarrow -F'_{yy} - F_{y1} - \frac{F_{y2}}{2} = 0, \text{ [N]} \tag{1}$$

$$\sum_i M_{1i} = 0 \Rightarrow F'_{yy} \cdot i - \frac{F_{y2}}{2} \cdot j = 0, \text{ [Nm]} \tag{2}$$

$$\sum_i F_{iy} = 0 \Rightarrow -F'_{yy} - F_{y6} + F_{TL} = 0, \text{ [N]} \tag{3}$$

$$\sum_i M_6 = 0 \Rightarrow F_{TL} \cdot (e-d) - F'_{yy} \cdot (e-b) = 0, \text{ [Nm]} \tag{4}$$

The force generated by passengers leaning on the door system is another considered force. Quantification of this value comes from the STN EN 12663 standard [14; 36; 37] and it is the customers' requirements [18] as well. Forces due to passengers have the value of $F_{CES} = \pm 1000$ N per one metre of an uncover width of the door, while their effect is considered in points A and B (Fig. 1, Fig. 3). Then, the value of the force F_{CES} is given by (5):

$$F_{CES} = \pm 1000 \cdot l_O, \text{ N} \tag{5}$$

where l_O – the uncover width of the door wing, m.

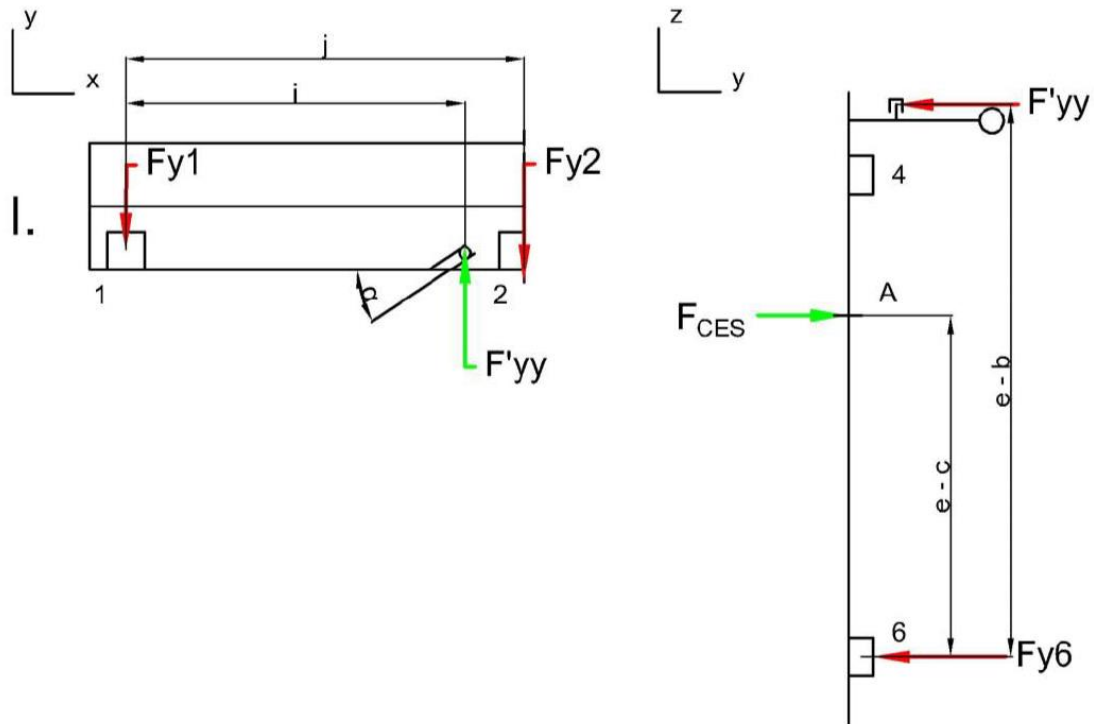

Fig. 3. Application of the law of action and reaction of forces on a door wing due to the force F_{CES}

For this design, the value is $l_O = 0.59$ m. The force F_{CES} is quantified on the value of 590 N. The entire task of calculation, geometry and action of forces due to passengers is presented in [23]. For performing of calculation, we can use again the symmetry of the door wing model. Therefore, the forces are in relation $F_{y1} = F_{y3}$, as well as $F_{y6} = F_{y7}$ and, thus, they are the same on both door wings (Fig. 1, Fig. 3). Hence, the equations of equilibrium for the force due to passengers have the following form (6-9):

$$\sum_i F_{iy} = 0 \Rightarrow -F'_{yy} - F_{y1} - \frac{F_{y2}}{2} = 0, \text{ [N]} \tag{6}$$

$$\sum_i M_{1i} = 0 \Rightarrow F'_{yy} \cdot i - \frac{F_{y2}}{2} \cdot j = 0, \text{ [Nm]} \tag{7}$$

$$\sum_i F_{iy} = 0 \Rightarrow -F'_{yy} - F_{y6} + F_{CES} = 0, \text{ [N]} \tag{8}$$

$$\sum_i M_6 = 0 \Rightarrow F_{CES} \cdot (e - c) - F'_{yy} \cdot (e - b) = 0, \text{ [Nm]} \tag{9}$$

The last missing force is the force, which arises due to acting of a gasket on the door system. Quantification of this force comes from the STN EN 12663 standard [34]. Forces due to the gasket are reduced to the centre of gravity and the value is of $F_{TES} = 50$ N per one metre of the gasket length of the door wing. Then, the value of the force F_{CES} is calculated by (10):

$$F_{TES} = -50 \cdot o_d, \text{ [N]} \tag{10}$$

A parameter o_d in eq. (10) represents the length of the door wing. For this door design the value of $o_d = 3.64$ m is valid, i. e. the length of one door wing. The entire task of calculation, geometry and acting of the force due to the gasket is described in [23]. The calculation is again performed by considering the door wing symmetry. Therefore, the forces are in the following relation $F_{y1} = F_{y3}$, as well as $F_{y6} = F_{y7}$ and they are the same for both door wings (Fig. 1, Fig. 4). The force F_{TES} is quantified to the value of -182.0 N.

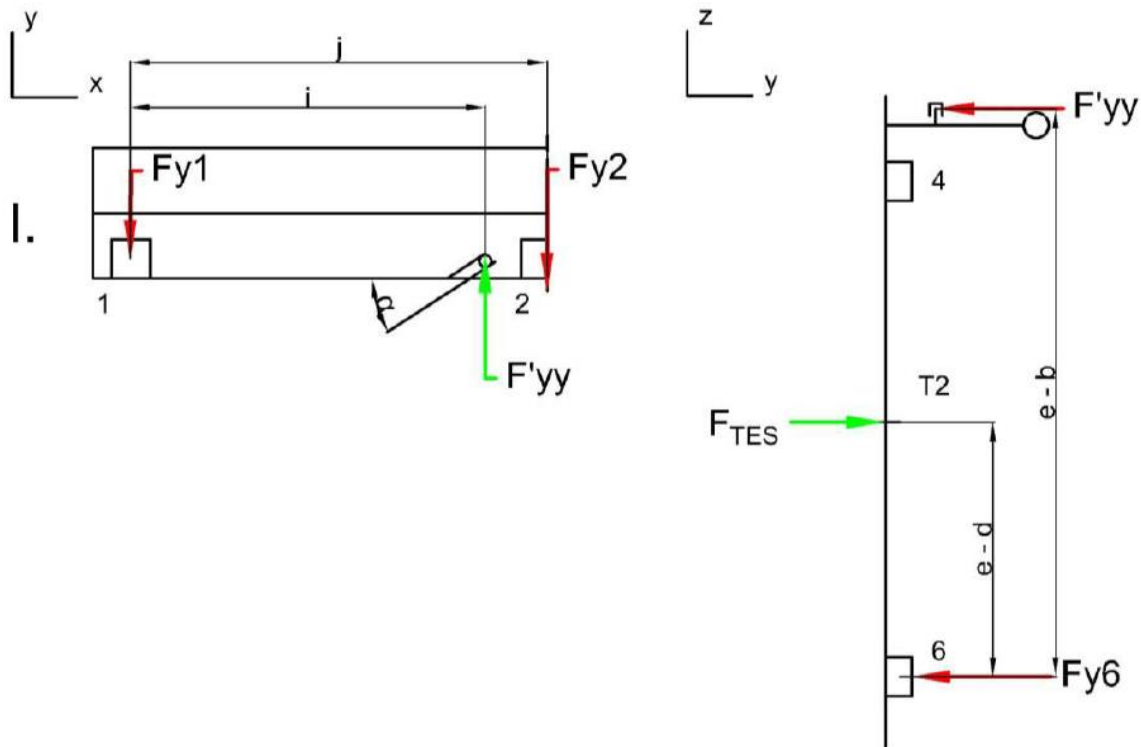

Fig. 4. Application of the law of action and reaction of forces on a door wing due to the force F_{TES}

Marking of reaction effects in Fig. 2-4 (red arrows) of all loading forces (F_{TL} , F_{CES} and F_{TES}) are the same. It is due to using of the superposition method and counting force effects for individual joint points in individual directions due to various forces. Equations of equilibrium for the force the passengers are in the form (11-14):

$$\sum_i F_{iy} = 0 \Rightarrow -F'_{yy} - F_{y1} - \frac{F_{y2}}{2} = 0, \text{ [N]} \tag{11}$$

$$\sum_i M_{1i} = 0 \Rightarrow F'_{yy} \cdot i - \frac{F_{y2}}{2} \cdot j = 0, [\text{Nm}] \quad (12)$$

$$\sum_i F_{iy} = 0 \Rightarrow -F'_{yy} - F_{y6} + F_{TES} = 0, [\text{N}] \quad (13)$$

$$\sum_i M_6 = 0 \Rightarrow -F_{TES} \cdot (e-d) - F'_{yy} \cdot (e-b) = 0, [\text{Nm}] \quad (14)$$

After obtaining of all described equations together with equations published in [21], they are organised and arranged as clearly as possible for further using.

Results and discussion

The parametric model created in the Microsoft Excel software and all derived equations were transferred to a matrix form (15):

$$A \cdot x = B, \quad (15)$$

where A – input matrix;
 x – unknown matrix;
 B – output matrix.

The following relation was used for calculation of unknown values (16):

$$x = A^{-1} \cdot B, \quad (16)$$

where A^{-1} – inverse matrix of the A matrix.

The A matrix (Table 2) includes values of considered accelerations in individual directions, which are included in the corresponding standards.

In this form, we will use the input matrix, the output matrix and the unknown matrix by searching the inverse matrix. This model will serve for prompt enumeration of force effects of the door on the wagon basic structure under changing of various input parameters. By the reason of quite large range of the problem, there is described an example of calculation of a particular load of the door. It is the calculation of the loading forces due to the net weight of the door, when the acceleration of $\pm 1g$ in the vertical direction is considered (y direction).

Table 2

Example of the system of equations in a matrix form for calculation of forces, results in N

Input matrix				Unknown matrix	Output matrix
A				X	B
-1	-0.5	0	1	F_{y1}	-392.4
0	0.439	0	-0.8226	F_{y2}	172.2636
0	0	-1	-1	F_{y6}	-490.5
0	0	0	1.973	F'_{yy}	463.032

Table 3

Example of the system of equations in a matrix form for calculation of forces, results in N

Inverse matrix				Calculated output matrix
A^{-1}				X
-1	-1.13895	0	0.031981	211.0081
0	2.277904	0	0.949723	832.1523
0	0	-1	-0.50684	255.8158
0	0	0	0.506842	234.6842

Table 4

Resulting values of reactions in analysed positions, considered acceleration $1g_y$

Reactions	Analysed position						
	1	2	3	4	5	6	7
R_x, N	0	0	0	0	0	0	0
R_y, N	-211.008	-832.152	-211.088	0	0	-255.816	-255.816
R_z, N	0	0	0	0	0	0	0

Table 5

Resulting values of reactions in analysed positions, considered acceleration $-1g_y$

Reactions	Analysed position						
	1	2	3	4	5	6	7
R_x, N	0	0	0	0	0	0	0
R_y, N	211.008	832.152	211.088	0	0	255.816	255.816
R_z, N	0	0	0	0	0	0	0

The created model is usable for various combinations of input forces. The maximal considered combined loads due to all forces, which are solved by the created parametric model, are listed in Table 6.

Table 6

Resulting values of forces acting to the wagon basic structure in the door joint points

Reactions	Analysed position						
	1	2	3	4	5	6	7
R_x, N	1536	1536	1536	0	0	1228	1228
R_y, N	241	3758	378	0	0	2876	708
R_z, N	-1335	-1365	-1335	-632	-632	0	0

The presented work has resulted in the planned parametric model, which will serve to calculate reactions of the metro door on a wagon basic structure. It will be very helpful. The reached results represent an illustrative example to get to know the principle in one particular case. However, the solved parametrized model is general. When a producer will want to modify the wagon door, e. g., because of different requirements of a customer, a designer is able quite simply to find out the loading forces of the door to the wagon basic structure. These forces are the main inputs to the subsequent strength analyses of the wagon body structure. Such an approach significantly makes much easier the process of designing the wagon body, saves time, as well as saves the production costs.

Conclusions

1. The authors have formed the equations of equilibrium for the joint points of a door wing depending on a type of the loading forces.
2. Equations have been arranged and implemented to the parametric model in the Microsoft Excel software. The values of reactions in joint points acting on the wagon basic structure have been enumerated by the created model.
3. The analysed results will serve for a dimensional calculation of the door attachments (screw joints).
4. All performed tasks, as well as the obtained results so far, indicate accuracy of the engineering design and it means that it can be implemented to the real metro wagon for a commercial metro operator.

Acknowledgements

This work was supported by the Cultural and Educational Grant Agency of the Ministry of Education of the Slovak Republic in the project No. KEGA 023ŽU-4/2020: Development of advanced virtual models for studying and investigation of transport means operation characteristics.

The work was supported by the Slovak Research and Development Agency of the Ministry of Education, Science, Research and Sport of the Slovak Republic in Educational Grant Agency of the

Ministry of Education of the Slovak Republic in the project No. VEGA 1/0558/18: Research of the interaction of a braked railway wheelset and track in simulated operational conditions of a vehicle running in a track on the test bench.

References

- [1] Rybicka I., Stopka O., Lupták V., Chovancová M., Drożdziel, P. Application of the methodology related to the emission standard to specific railway line in comparison with parallel road transport: A case study. *MATEC Web of Conferences*, vol. 244, 2018.
- [2] Melnik R., Koziak S., Sowiński B., Chudzikiewicz A. Reliability analysis of metro vehicles operating in Poland. *Transportation Research Procedia*, vol. 40, 2019, pp. 808-814.
- [3] Kendra M., Babin M., Barta, D. Changes of the infrastructure and operation parameters of a railway line and their impact to the track capacity and the volume of transported goods. *Procedia Social and Behavioral Sciences*, vol. 48, 2012, pp. 743-752.
- [4] Harušinec J., Suchánek A., Loulová M., Strážovec P. Design of a device to simulate environmental influences on the course of brake tests. *MATEC Web of Conferences*, vol. 157, 2018.
- [5] Dvořák Z., Leitner B., Novák L. Software Support for Railway Traffic Simulation under Restricted Conditions of the Rail Section. *Procedia Engineering*, vol. 134, 2016, pp. 245-255.
- [6] Leitner B. Autoregressive Models in Modelling and Simulation of Transport Means Working Conditions. *Proceedings of 14th International Scientific Conference on Transport Means "TRANSPORT MEANS 2010"*, October 21-22, 2010, Kaunas, Lithuania, pp. 21-24.
- [7] Luskova M., Dvorak Z., Leitner B. Impact of extreme weather events on land transport infrastructure. *Proceedings of 19th International Scientific Conference on Transport Means "TRANSPORT MEANS 2015"*, October 22-23, 2015, Kaunas, Lithuania, pp. 306-309.
- [8] Kletska O., Falendysh A., Vasylenko O., Onyshchenko A. Definition of the coefficient of blackness for inhomogeneous surfaces under conducting thermography. *MATEC Web of Conferences*, vol. 178, 2018.
- [9] Mikhailov E., Semenov S., Tkachenko V., Sapronova S. Reduction of kinematic resistance to movement of the railway vehicles. *MATEC Web of Conferences*, vol. 235, 2018.
- [10] Mikhailov E., Sapronova S., Tkachenko V., Semenov S., Smyrnova I., Kholostenko Y. Improved solution of guiding of railway vehicle in curves. *Proceedings of 23rd International Scientific Conference on Transport Means "TRANSPORT MEANS 2019"*, October 2-4, 2019, Kaunas, Lithuania, pp. 916-921.
- [11] Melnik R., Sowiński B. Analysis of dynamics of a metro vehicle model with differential wheelsets. *Transport Problems*, vol. 12, 2017, pp. 113-124.
- [12] Gerlici J., Sakhno V., Yefymenko A., Verbitskii V., Kravchenko A., Kravchenko K. The stability analysis of two-wheeled vehicle model. *MATEC Web of Conferences*, vol. 157, 2018.
- [13] Hauser V., Nozhenko O., Kravchenko K., Loulova M., Gerlici J., Lack T. Proposal of a steering mechanism for tram bogie with three axle boxes. *Procedia Engineering*, vol. 192, 2017, pp. 289-294.
- [14] Štastniak P., Kurčík P., Pavlík A. Design of a new railway wagon for intermodal transport with the adaptable loading platform. *MATEC Web of Conferences*, vol. 235, 2018.
- [15] Harušinec J., Suchánek A., Štastniak P., Strážovec P. Brake actuator optimization of the brake test stand as a tool for improvement railway safety. *MATEC Web of Conferences*, vol. 235, 2018.
- [16] Lack T., Gerlici J. Analysis of vehicles dynamic properties from: The point of view of passenger comfort. *Komunikacie*, vo. 10, 2008, pp. 10-18.
- [17] Gerlici J., Nozhenko O., Cherniak G., Gorbunov M., Domin R., Lack T. The development of diagnostics methodological principles of the railway rolling stock on the basis of the analysis of dynamic vibration processes of the rail. *MATEC Web of Conferences*, vol. 157, 2018.
- [18] Fomin O., Lovska A. Improvements in passenger car body for higher stability of train ferry. *Engineering Science and Technology, an International Journal*, vol. 23, 2020, pp. 1455-1465.
- [19] Koziak S., Chudzikiewicz A., Opala M., Melnik R. Virtual software testing and certification of railway vehicle from the point of view of their dynamics. *Transportation Research Procedia*, vol. 40, 2019, pp. 729-736.
- [20] Metro "Prague Public Transit Company". [online] [26.01.2021]. Available at: <https://www.dpp.cz/en/company/about-the-company/company-profile>

- [21] Jaňák, M. A model of force effect of a metro door vehicle on a basic structure. Thesis 2017. University of Zilina. (In Slovak).
- [22] Blatnický M., Dižo J., Vaičiūnas G. Preparation of parametric model of underground metro door force acting on coarse structure. Proceedings of the International Conference “TRANSBALTICA”, May 2-3, 2019, Vilnius, Lithuania, pp. 320-330.
- [23] Blatnický M., Dižo J., Barta D., Drożdźiel P. Design of a metro door system and determination of main loads. Scientific Journal of Silesian University of Technology. Series Transport, vol. 105, 2019, pp. 49-64.
- [24] EN 45545-2 standard “European Union Standard Fire Testing to Railway Components.”
- [25] Fomin O., Lovska A., Kudelya V., Smyrnova I. Determining the dynamic loading and strength of the bearing structure of a covered wagon when firing from it. Eastern-European Journal of Enterprise Technologies, vol. 4, 2020, pp. 33-41.
- [26] Zvolensky P., Kasiar L., Volna P., Barta D. Simulated computation of the acoustic energy transfer through the structure of porous media in application of passenger carriage body. Procedia Engineering, vol.187, 2017, pp. 100-109.
- [27] EN ISO 10140-2 standard “Acoustics – Laboratory measurement of sound insulation of building elements – Part 2: Measurement of airborne sound insulation.”
- [28] Gerlici J., Gorbunov M., Kravchenko K., Kostyukevich A., Nozhenko O., Lack T. Experimental rigs for wheel/rail contact research. Manufacturing Technology, vol. 16, 2016, pp. 909-916.
- [29] ISO 12567-1 standard “Thermal performance of windows and doors – Determination of thermal transmittance by hot box method – Part 1: Complete windows and doors.”
- [30] EN 50155:2003-12 standard “Railway applications. Electronic equipment used on rolling stock.”
- [31] EN 50121-3-2:2015-12 standard “Railway applications. Electromagnetic compatibility. Part 3-2: Rolling stock. Apparatus.”
- [32] STN EN 50153/A2 standard “Railway applications – Rolling stock – Protective provisions relating to electrical hazards”
- [33] EN 50125-1:2015-04 standard “Railway applications. Environmental conditions for equipment. Part 1: Equipment on board rolling stock.”
- [34] STN EN 14752 standard “Railway applications – Bodyside entrance systems for rolling stock”
- [35] Kurčik P., Blatnický M., Dižo J., Pavlík A., Harušinec J. Design of a technical solution for a metro door system. Transportation Research Procedia, vol. 40, 2019, pp. 767-773.
- [36] STN EN 12663-1 standard “Railway applications. Structural requirements of railway vehicle bodies. Part 1: Locomotives an passenger rolling stock (and alternative method for freight wagons)”
- [37] Fomin O., Gerlici J., Lovska A., Kravchenko K., Prokopenko P., Fomina A., Hauser V. Durability determination of the bearing structure of an open freight wagon body made of round pipes during its transportation on the railway ferry. Communications – Scientific Letters of the University of Zilina, vol. 21, 2019, pp. 28-34.